

# HYDRAULIC TORQUE WRENCH

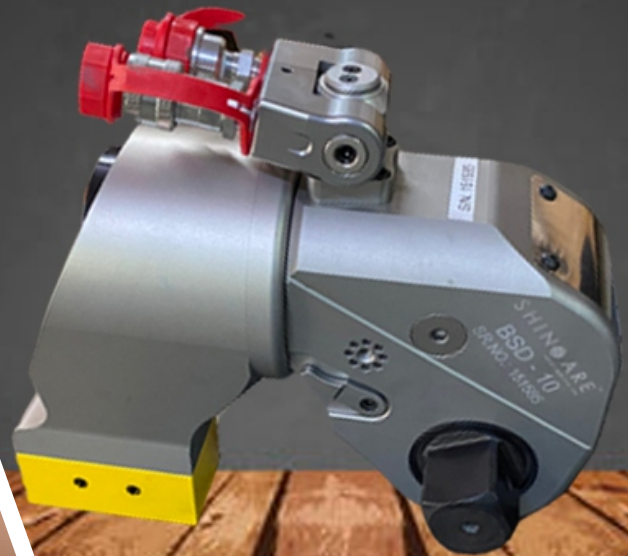

TUBE TOOLS

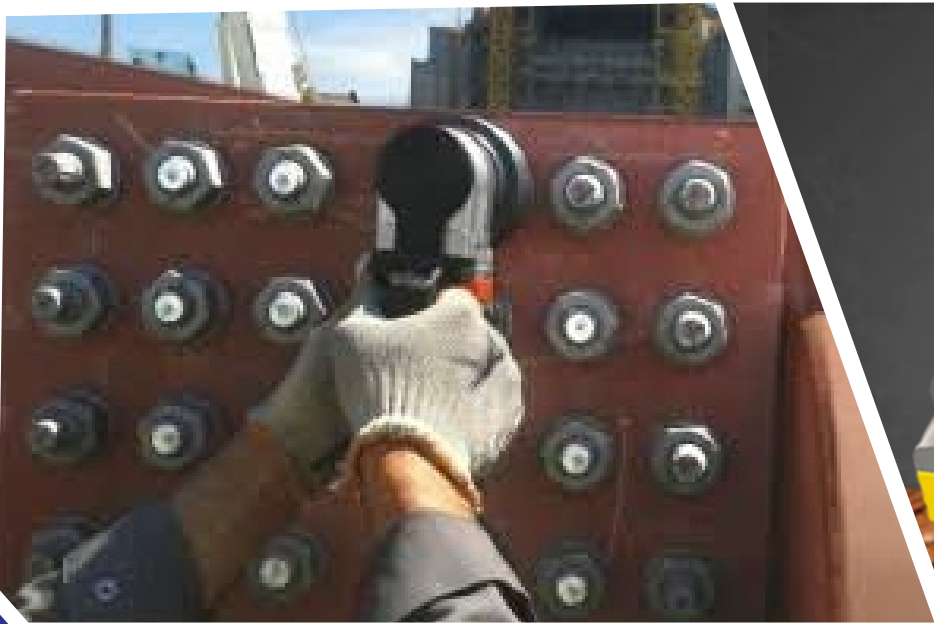

**SHINGARE**  
INDUSTRIES PVT LTD

**MANUFACTURER & EXPORTER OF**  
Tube Cleaners, Tube Tools,  
Tube Expanders, Bolting Tools, Impact Sockets,  
Pipe Beveling Machines, Pipe Cold Cutting Machines,  
High Pressure Water Jet Cleaning Machines & Tapping Machines

Education is necessary but not a pre-requisite for success in life. Bhartiya Industries is the best example of this theory. **Mr. Suryakant Shingare** (HARIBHAI), the founder of the company is a non-matriculate technocrat with more than 10 years experience in flexible shaft manufacturing. He founded this company in 1989.



### Basic Products:

Engineering products is our forte. We manufacture engineering products such as tube expander, tube cleaner, tube tools, hydraulic tube expansion, tube pulling, and pipe beveling machines. We also deal in manufacture of flexible shaft grinders, construction equipment, hydraulic torque wrench, impact socket, pneumatic tapping machines, and many more...

### Brief History of the Company:



We were a small industry until 2003 engaged in production and supply of different types of flexible shafts for tube cleaning, brushes, flexible shaft grinder, and concrete vibrators. The year 2003 was a watershed year for the company.

**Mr. Pradip Shingare**, son of **Mr. Hari Shingare**, graduated from Mumbai University with a degree in Mechanical Engineering. He had great plans to take the company forward on the route to expansion. He ventured into export of the engineering products. By 2008, the company acquired the reputation as the largest exporter of tube cleaning machines and flexible shafts in India.

The year 2009 saw the expansion of the company into manufacture of products such as Tube expander, tube tools, and tube pulling machines. The company witnessed a record double-digit growth in this product range. In 2011, the company started developing a product range of pipe beveling machines. These machines are extremely popular in India as well as in the overseas market. The year 2013 witnessed the company foray into imports of different types of tools such as tapping tools, grinding tools, etc making us the leading player in India in these categories.

The year 2015 saw us entering into the sugar industry component with the manufacture of the Heavy Duty Sugar Dust Collector machine, FlexRepair40 machine.

In 2016, we added **SHINGARE INDUSTRIES PVT. LTD.** a new company in our group. We were awarded ISO 9001:2015 certification for strictly followed quality norms and processes.

### Dedicated Staff:

We have a dedicated team of more than 40 people, many of whom are with us since the early days of the company. We have an excellent blend of youth, knowledge, and experience in our ranks.

### Export oriented:

We export over 60% of our products to more than 55 countries all over the globe.

### Expansion:

We feel the need to expand our business to enable us to serve the people of this country better. With this aim in mind, we established a new company in the name of SHINGARE INDUSTRIES PVT. LTD.

**Our main motto of business is “Growth with Trust.”**

Our mission is to innovate and create an import substitute products in India.



# CONTENTS

Sr. No.	Product	Page
1.	BSD Hydraulic Torque Wrenches-Square Drive	4
2.	BSD Series Accessories	5
3.	Heavy Duty Impact Sockets	6
4.	BXD Hydraulic Torque Wrenches-Low Profile Hexagon / Dimensions	7
5.	BXD Series Hex / Ratchet Links Reducers	8-9
6.	BHPE / Electric Driven Torque Wrench Pumps	10
7.	BHPA / Air Driven Torque Wrench Pumps	11
8.	Torque Wrench Pump Accessories	12
9.	Top Side Bolt Tensioner	13-14
10.	Ts series Multi-Stage Bolt Tensioner	15
11.	Electric Powerpack For Bolt Tensioner (BETP)	16
12.	Air Operated Powerpack For Bolt Tensioner (BATP)	17
13.	Hand Pump For Bolt Tensioner (SHP)	18

## Our Successful Participation in Trade Fairs and Conventions in INDIA and Overseas.



SISSTA BENGALURU 2015



SISSTA, CHENNAI 2016



STAI, NEW DELHI 2016



SISSTA, TIRUPATI 2017



MAHATECH, PUNE 2015

## BSD HYDRAULIC TORQUE WRENCHES – SQUARE DRIVE

### TECHNICAL SPECIFICATION:

Torque Capacity up to 36872 Nm

Torque Accuracy of +/- 3 %

Working Pressure 700 bar

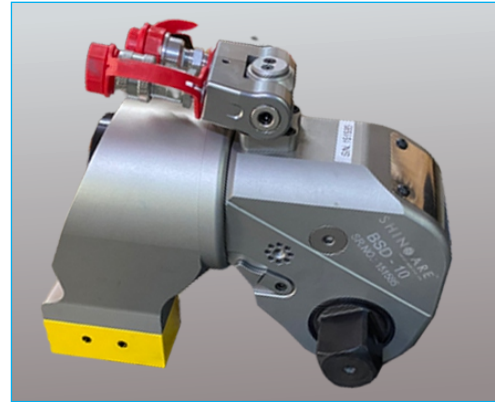

### FEATURES:

- Compact, lightweight aluminium body construction
- Output torque capacities from 183 to 34725 Nm
- Choice of square drive sizes from 3/4" to 2 1/2"
- Reversible square drive for tightening or loosening applications
- Multi-position reaction arm with safety lock feature
- Fitted with 360° uni-swivel quick release couplings for easy positioning of hydraulic hoses during operation
- The 360°×180° degree swivel is free to operation with no space limitation.
- Optional Allen hex drives available from 1/2" to 2 1/4" and 14 to 60 mm
- The new locking coupler ensures the oil keep free access.

PART	BSD-1	BSD-3	BSD-5	BSD-8	BSD-10	BSD-20	BSD-25
Torque (NM)	183-1837	451-4512	752-7528	1078-10780	1551-15516	2666-26664	3472-34725
Bolt Size A/F of Nut in mm	16-36	22-48	27-56	30-64	36-72	42-90	48-100
Weight (Kg)	2.5	5	10	11	15	26.5	35
Square Drive	3/4"	1"	1-1/2"	1-1/2"	1-1/2"	2-1/2"	2-1/2"

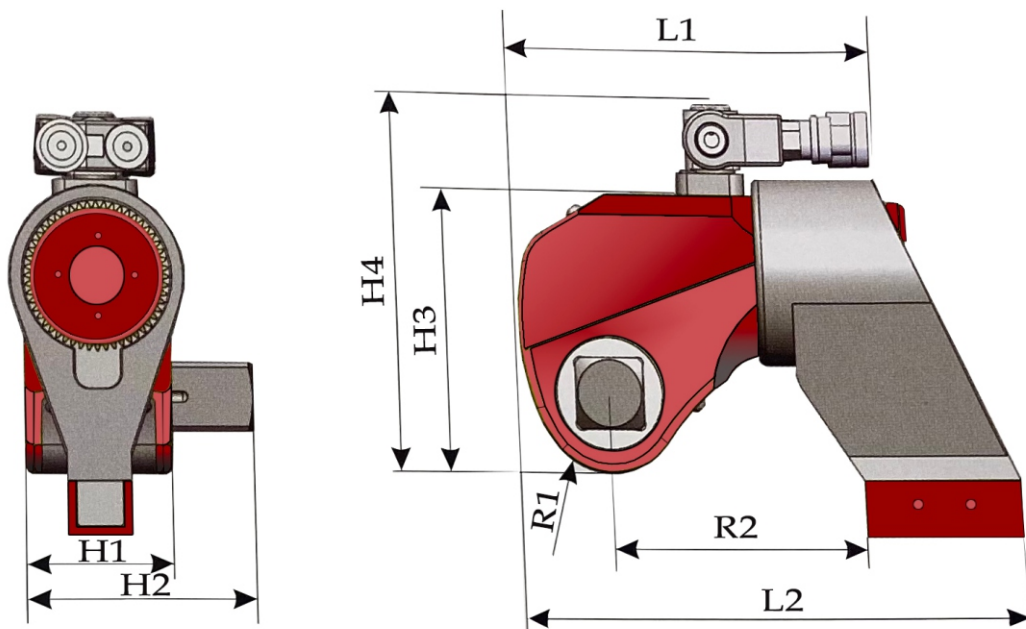

# HYDRAULIC TORQUE WRENCH

## DIMENSIONS

Model No. Dimension	BSD-1	BSD-3	BSD-5	BSD-8	BSD-10	BSD-20	BSD-25
L1	144.5	178	210.5	222	245.5	307.5	323
L2	173	229	270.5	293	317.5	383.5	401
H1	50	68	80	90	100	120	137
H2	72	95	123	134	142	183	200
H3	96	127	149	167	182	220	247
H4	131	176.5	199	217	232	270	297
R	91.5	123.5	140	165	178	213	228
R1	26	34	39	47	51	59	66
R2	85	114	137	153	154	186	199
R3	29	40	46.5	47	58.5	71	72.5

## ACCESSORIES

For Special Reaction Arm, consult to SIPL!

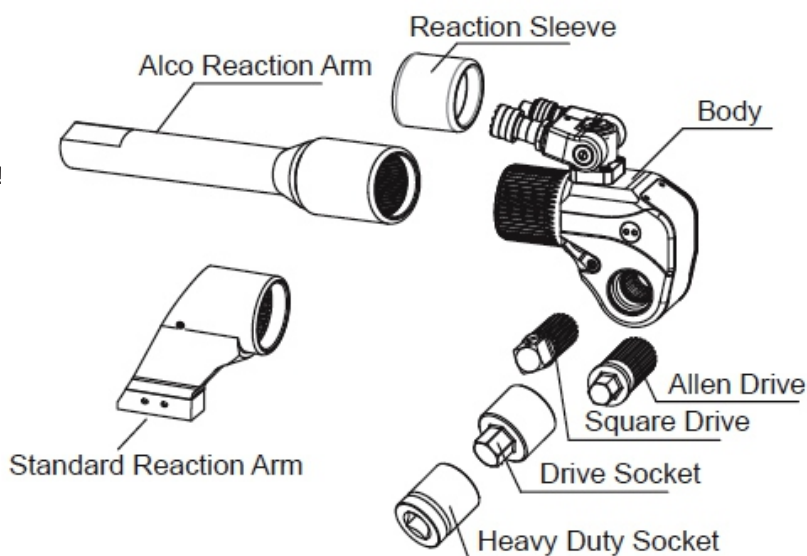

### IMPACT SOCKETS (Standard and Deep)

Suitable for 3/4", 1", 1.1/2" and 2.1/2" Square Drive from A/F 14 mm to 165 mm



## HEAVY DUTY IMPACT SOCKETS

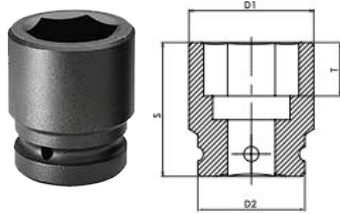

### 6 POINTS IMPACT SOCKETS

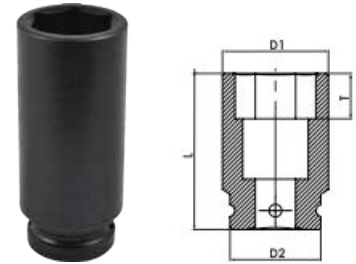

Model No.	Square Drive	Nut A/F		D1	D2	S	T	L
		inch	mm					
S-12M24	3/4"	-	24	40	44	46	21	90
S-12M27	3/4"	-	27	41	44	48	23	90
S-1217	3/4"	1.1/16	-	41	44	48	23	90
S-1230	3/4"	-	30	44	44	52	24	90
S-1220	3/4"	1.1/4	-	49	44	52	24	90
S-12M32	3/4"	-	32	49	44	52	26	90
S-12M36	3/4"	-	36	52	44	55	28	90
S-1223	3/4"	1.7/16	-	52	44	56	28	90
S-12M41	3/4"	-	41	57	44	59	36	90
S-1226	3/4"	1.5/8	-	57	44	59	36	90
S-12M46	3/4"	-	46	67	44	64	37	90
S-1229	3/4"	1.13/16	-	67	44	64	36	90
S-12M50	3/4"	-	50	70	54	67	39	90
S-1232	3/4"	2	-	73	54	67	39	90
12M55DH	3/4"	-	55	78	54	71	41	94
S-1635	3/4"	2.3/16	-	78	54	71	41	94
12M60DH	3/4"	-	60	82	52	75	45	98
S-1638	3/4"	2.3/8	-	82	54	75	45	98
S-12M24	1"	-	24	42	54	55	21	100
S-12M27	1"	-	27	46	54	55	23	100
S-1217	1"	1.1/16	-	46	54	55	23	100
S-12M30	1"	-	30	50	54	57	24	100
S-1220	1"	1.1/4	-	51	54	57	24	100
S-12M32	1"	-	32	51	54	57	26	100
S-12M36	1"	-	36	54	54	60	28	100
S-1223	1"	1.7/16	-	54	54	60	28	100
S-12M41	1"	-	41	63	54	64	36	100
S-1226	1"	1.5/8	-	63	54	64	36	100
S-12M46	1"	-	46	70	54	69	36	100
S-1229	1"	1.13/16	-	70	54	69	36	100
S-1250	1"	-	50	73	54	72	36	100
S-1232	1"	2	-	73	54	72	39	100
12M55DH	1"	-	55	82	54	76	41	105
S-1635	1"	2.3/16	-	82	54	80	41	105
12M60DH	1"	-	60	86	54	82	45	112
S-1638	1"	2.3/8	-	88	54	85	45	112
S-16M65	1"	-	65	92	54	85	46	118
S-1641	1"	2.9/16	-	92	54	85	46	118
S-16M70	1"	-	70	96	54	88	50	124
S-1644	1"	2.3/4	-	96	54	88	50	124
S-16M75	1"	-	75	100	86	92	57	124
S-1647	1"	2.15/16	-	100	86	92	57	124
S-16M100	1"	-	100	135	86	112	62	143
S-1650	1"	3.1/8"	-	105	86	97	57	132
S-16M80	1"	-	80	105	86	97	62	132
S-16M85	1"	-	85	115	86	100	62	132
S-1656	1"	3.1/2"	-	121	86	104	62	140
S-16M90	1"	-	90	127	86	104	62	140
S-16M95	1"	-	95	135	86	106	62	140

Model No.	Square Drive	Nut A/F		D1	D2	S	T	L
		inch	mm					
S-1662	1"	3.7/8"	-	135	86	112	62	143
S-16M36	1.1/2"	-	36	64	86	80	28	130
S-16M41	1.1/2"	-	41	69	86	83	32	130
S-16M46	1.1/2"	-	46	76	86	86	36	130
S-1629	1.1/2"	1.13/16	-	76	86	86	36	130
S-12M50	1.1/2"	-	50	81	86	90	39	130
S-1232	1.1/2"	2	-	81	86	90	39	130
12M55DH	1.1/2"	-	55	88	86	95	41	140
S-1635	1.1/2"	2.3/16	-	88	86	95	41	140
S-16M60	1.1/2"	-	60	96	86	98	45	140
S-1638	1.1/2"	2.3/8	-	96	86	98	45	140
S-16M65	1.1/2"	-	65	102	86	102	46	140
S-1641	1.1/2"	2.9/16	-	102	86	102	46	140
S-16M70	1.1/2"	-	70	108	86	102	50	150
S-1644	1.1/2"	2.3/4	-	108	86	102	50	150
S-16M75	1.1/2"	-	75	116	86	108	57	150
S-1647	1.1/2"	2.15/16	-	116	86	108	57	150
S-16M80	1.1/2"	-	80	120	86	110	62	150
S-1650	1.1/2"	3.1/8	-	120	86	110	62	150
S-16M85	1.1/2"	-	85	130	86	115	62	170
S-16M90	1.1/2"	-	90	135	125	118	65	170
S-1656	1.1/2"	3.1/2	-	135	125	118	65	170
S-16M95	1.1/2"	-	95	140	125	123	70	170
S-16M100	1.1/2"	-	100	148	125	128	75	190
S-1662	1.1/2"	3.7/8	-	148	125	128	75	190
S-16M105	1.1/2"	-	105	155	125	133	80	190
S-1668	1.1/2"	4.1/4	-	155	125	133	80	190
S-16M110	1.1/2"	-	110	161	150	138	85	200
S-16M115	1.1/2"	-	115	161	150	143	94	200
S-1670	1.1/2"	4.5/8	-	175	150	149	94	200
S-16M80	2.1/2"	-	80	135	125	140	62	190
S-1650	2.1/2"	3.1/8	-	135	125	140	62	190
16M85DH	2.1/2"	-	85	140	125	140	62	190
16M90DH	2.1/2"	-	90	145	125	140	65	190
16M95DH	2.1/2"	-	95	155	125	150	70	190
1662DH	2.1/2"	3.7/8	-	155	125	150	70	190
S-24M100	2.1/2"	-	100	160	125	150	75	200
S-24M105	2.1/2"	-	105	165	125	160	80	200
S-24M110	2.1/2"	-	110	174	150	160	85	210
S-24M115	2.1/2"	-	115	180	150	170	90	210
S-2472	2.1/2"	4.1/2	-	180	150	170	90	210
S-2480	2.1/2"	5	-	195	150	175	98	220
S-24M130	2.1/2"	-	130	195	150	175	98	220
S-2482	2.1/2"	5.3/8	-	205	150	180	102	220
S-40M145	2.1/2"	-	145	220	150	180	105	230
S-4092	2.1/2"	5.3/4	-	220	150	180	105	230
S-4098	2.1/2"	6.1/8	-	230	180	190	110	250
S-40104	2.1/2"	6.1/2	-	240	180	200	120	-
S-40110	2.1/2"	6.7/8	-	255	180	200	120	-



## BXD HYDRAULIC TORQUE WRENCHES – LOW PROFILE HEXAGON

### TECHNICAL SPECIFICATION:

Torque Capacity up to 48327 Nm

Torque Accuracy of +/- 3 %

Working Pressure 700 bar



### FEATURES:

- Lightweight
- Output torque capacities from 232 to 44593 Nm
- Low profile design for direct in-line reaction
- Narrow cassette head design makes it ideal for limited access applications
- Ratchet head can be easily changed by simply withdrawing/inserting a single pin
- Imperial ratchet heads available with across flat (AF sizes) sizes from 1 1/16" to 6 7/8"
- Metric ratchet heads available with across flat (AF sizes) sizes from 24 to 175 mm
- Fitted with 360° x 180° swivel with quick release couplings for easy positioning of hydraulic hoses

## ACCESSORIES

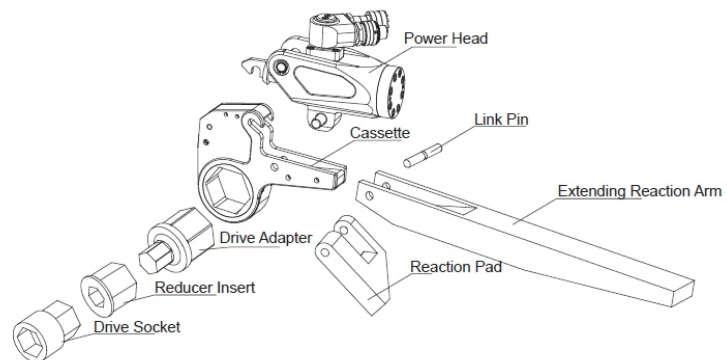

MODEL NO.	TORQUE NM	NUT SIZES IN MM	POWER HEAD WEIGHT IN KGS	LINK / CASSATE WEIGHT IN KGS
BXD-2	232-2328	19-55	1	1.6
	241-2414	60	1	1.7
BXD-4	585-2510	34-36	-	-
	585-5021	41	2	4.4
	585-5858	46-65	2	4.6
	647-6474	70-80	-	-
BXD-8	1000-11000	41-95	3.0	8.2
	1120-12100	100-105	3.5	9
BXD-14	1852-18521	50-117	5.5	11.6
BXD-32	4188-41882	110-155	11.4	29
	4459-44593	160-175	11.4	30

# HYDRAULIC TORQUE WRENCH

## BXD HYDRAULIC TORQUE WRENCHES – LOW PROFILE HEXAGON

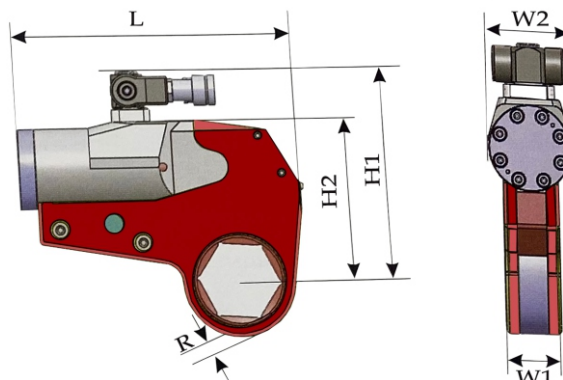

Dimension Model No.	L	H1	H2	W1	W2
BXD-2	196.4	125.9	102.3	32	51
	196.4	128.5	105	32	51
BXD-4	245	177	135.7	42	66
	246	187	145.7	42	66
BXD-8	300	207	169	53	83
	301	216	178	53	83
BXD-14	361	239	204	64	99
	430	303	272	85	131
BXD-32	441	315	285	85	131

## BXD SERIES HEX / RATCHET LINKS

BXD-2				BXD-4				BXD-8				BXD-14				BXD-32			
Type	R	A	Max Torque	Type	R	A	Max Torque	Type	R	A	Max Torque	Type	R	A	Max Torque	Type	R	A	Max Torque
BXD-2-19	27	16	2328	BXD-4-34	36	16	2510	BXD-8-41	46	22	10941	BXD-14-50	60	31	18521	BXD-32-85	78	28	41882
BXD-2-22	27	14	2328	BXD-4-36	36	15	2510	BXD-8-46	46	19	10941	BXD-14-55	60	28	18521	BXD-32-90	78	28	41882
BXD-2-27	27	11	2328	BXD-4-41	39	15	5021	BXD-8-50	46	17	10941	BXD-14-60	60	25	18521	BXD-32-95	83	28	41882
BXD-2-30	29	12	2328	BXD-4-46	42	15	5858	BXD-8-55	50	18	10941	BXD-14-65	60	22	18521	BXD-32-100	83	25	41882
BXD-2-32	29	11	2328	BXD-4-50	44	15	5858	BXD-8-60	52	17	10941	BXD-14-70	60	19	18521	BXD-32-105	89	28	41882
BXD-2-34	31	11	2328	BXD-4-55	46	14	5858	BXD-8-65	55	17	10941	BXD-14-75	63	19	18521	BXD-32-110	89	25	41882
BXD-2-36	31	10	2328	BXD-4-60	50	15	5858	BXD-8-70	58	17	10941	BXD-14-80	66	19	18521	BXD-32-115	95	28	41882
BXD-2-41	34	10	2328	BXD-4-65	53	15	5858	BXD-8-75	60	17	10941	BXD-14-85	69	19	18521	BXD-32-117	95	27	41882
BXD-2-46	37	10	2328	BXD-4-70	56	15	6474	BXD-8-80	63	16	10941	BXD-14-90	72	20	18521	BXD-32-120	95	25	41882
BXD-2-50	40	11	2328	BXD-4-75	59	15	6474	BXD-8-85	66	16	10941	BXD-14-95	74	19	18521	BXD-32-125	101	29	41882
BXD-2-55	43	11	2328	BXD-4-80	61	15	6474	BXD-8-90	69	17	10941	BXD-14-100	77	19	18521	BXD-32-130	101	26	41882
BXD-2-60	46	11	2414	-	-	-	-	BXD-8-95	71	16	10941	BXD-14-105	80	19	18521	BXD-32-135	104	26	41882
-	-	-	-	-	-	-	-	BXD-8-100	75	17	11774	BXD-14-110	83	19	18521	BXD-32-140	110	29	41882
-	-	-	-	-	-	-	-	BXD-8-105	78	17	11774	BXD-14-115	87	20	18521	BXD-32-145	110	26	41882
-	-	-	-	-	-	-	-	-	-	-	-	BXD-14-117	87	19	18521	BXD-32-150	116	29	41882
-	-	-	-	-	-	-	-	-	-	-	-	-	-	-	-	BXD-32-155	116	26	41882
-	-	-	-	-	-	-	-	-	-	-	-	-	-	-	-	BXD-32-160	128	36	44593
-	-	-	-	-	-	-	-	-	-	-	-	-	-	-	-	BXD-32-165	128	33	44593
-	-	-	-	-	-	-	-	-	-	-	-	-	-	-	-	BXD-32-170	128	30	44593
-	-	-	-	-	-	-	-	-	-	-	-	-	-	-	-	BXD-32-175	128	27	44593



## BXD SERIES HEX / RATCHET LINKS

### REDUCERS



Wrench Model	Cassette	Nut Size (S)	Locking ring / Reducer		
BXD2	BXD2-50	50	50/41	50/36	50/32
	BXD2-46	46	46/36	46/32	46/30
	BXD2-41	41	41/32	41/30	41/27
	BXD2-36	36	36/30	36/27	
	BXD2-32	32	32/27		
	BXD2-30	30			
BXD4	BXD4-65	65	65/55	65/50	65/46
	BXD4-60	60	60/50	60/46	60/41
	BXD4-55	55	55/46	55/41	55/36
	BXD4-50	50	50/41	50/36	50/32
	BXD4-46	46	46/36	46/32	46/30
	BXD4-41	41	41/32	41/30	41/27
	BXD4-36	36	36/30	3/27	
	BXD4-32	32	32/27		
	BXD4-30	30			
BXD8	BXD8-90	90	90/80	90/75	90/70
	BXD8-85	85	85/75	85/70	85/65
	BXD8-80	80	80/70	80/65	80/60
	BXD8-75	75	75/65	75/60	75/55
	BXD8-70	70	70/60	70/55	70/50
	BXD8-65	65	65/55	65/50	65/45
	BXD8-60	60	60/50	60/46	
	BXD8-55	55	55/46	55/41	
BXD14	BXD14-115	115	115/105	115/100	115/95
	BXD14-110	110	110/100	110/95	110/90
	BXD14-105	105	105/95	105/90	105/85
	BXD14-100	100	100/90	100/85	100/80
	BXD14-95	95	95/85	95/80	95/75
	BXD14-90	90	90/80	90/75	90/70
	BXD14-85	85	85/75	85/70	85/65
	BXD14-80	80	80/70	80/65	
	BXD14-75	75	75/65		
BXD32	BXD32-155	155	155/145	155/130	155/120
	BXD32-145	145	145/130	145/120	145/115
	BXD32-130	130	130/120	130/115	130/110
	BXD32-120	120	120/110	120/105	120/100
	BXD32-115	115	115/105	115/100	115/95
	BXD32-110	110	110/100	110/95	110/90
	BXD32-105	105	105/95	105/90	100/80
	BXD32-100	100	100/90	100/85	100/80
	BXD32-95	95	95/85	95/80	
	BXD32-90	90	90/80		
BXD32-85	85				
BXD32-80	80				

# HYDRAULIC TORQUE WRENCH



## BHPE | ELECTRIC DRIVEN TORQUE WRENCH PUMPS

### TECHNICAL SPECIFICATION:

Working Pressure 700 bar

High Flow 3 – stage pump unit

Compact and Lightweight

### FEATURES

- Low noise operation (<88 dB)
- Supplied fitted with one set of quick connect couplers
- Automatically activated oil cooling heat exchanger fitted as standard
- Adjustable torque setting pressure relief valve with locking nut
- Analogue or digital gauge options
- Remote hand pendant controller with 5 metres cable for easy operation
- Choice of manual operation with auto retract or fully automatic operation
- Multi-outlet 4-way split block for simultaneous operation of up to 4 torque wrenches
- Factory fitted roll bar protection and carrying frame
- Supplied with 5 mtr twin hoses and quick connect couplings suitable for BXD and BSD torque wrenches

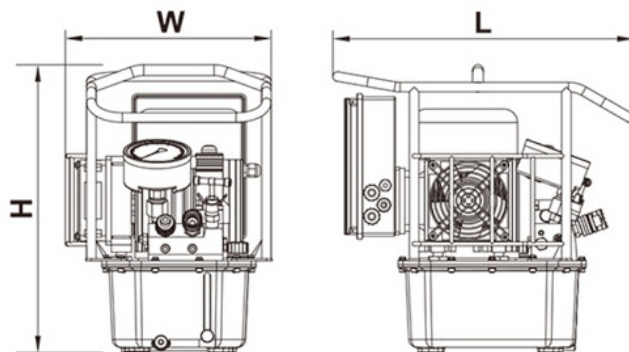

TYPE	BHPE-1000	BHPE-4000
Working Pressure	70 MPa	70 MPa
Drive	Electric	Electric
Voltage	220 V/50Hz	220 V/50Hz
Power	1.1 kW	1.1 kW
Tank Capacity	5.5L	5.5L
Flow Rate	7-1.6-0.8 L/min	7-1.6-0.8 L/min
Oil Cooler	Yes	Yes
Weight	25kg	27kg
Oil Outputs	4x1/4"NPT	8x1/4"NPT
LxWxH(mm)	445x304x304x426	461x304x426

## BHPA | AIR DRIVEN TORQUE WRENCH PUMPS

### TECHNICAL SPECIFICATION:

Working Pressure 700 bar

High Flow 3 – stage pump unit

Compact and Lightweight



### FEATURES

- The Single valve block can be replaced by component FP-4, thereby allowing 2 or 4 tools to be driven simultaneously
- Three stage with air drive
- Supporting continuous operation with steel frame
- 100mm diameter gauge ,aluminium oil tank with oil level indicator
- Variable pressure adjustment between 1000~10000 psi
- Designed for continuous operation
- Supplied with 5 mtr twin hoses and quick connect couplings suitable for BXD and BSD torque wrenches

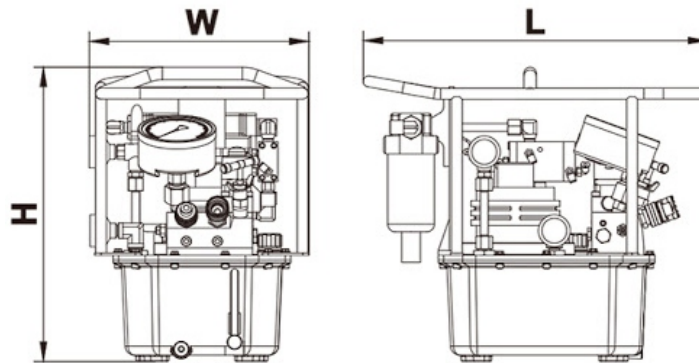

TYPE	BHPA-2	BHPA-4
Working Pressure	70 MPa	70 MPa
Drive	Air	Air
Air Pressure	≥3.4 m³/min	≥3.4 m³/min
Power	4.0HP	4.0HP
Tank Capacity	5.5L	5.5L
Flow Rate	10-2-21.1 L/min	10-2-21.1 L/min
Oil Cooler	Yes	Yes
Weight	19kg	21kg
Pill Outputs	4x1/4"NPT	8x1/4"NPT
Air in	4~8 bar	4~8 bar
LxWxH(mm)	442x282x377	460x282x377

## TORQUE WRENCH PUMP ACCESSORIES



- High quality hydraulic torque wrench bonded twin hose sets
- Maximum working pressure of 700 bar with 4:1 safety factor
- Ergonomically designed protective, strain reliever hand grips on both ends

Hose length up to 100 meters

Supplied with quick connect couplings

Working pressure 700 bar



Model	Photograph	Max operating Pressure (Mpa)	Hose end		Hose Length (M)
			End one	End two	
BH64 series twin hydraulic hose		72	1/4"NPT	1/4"NPT	6 9
BH74 series hydraulic hose		72	1/4"NPT	1/4"NPT	6 9
Bh78 series hydraulic hose		100	3/8"NPT	3/8"NPT	1.8 4.5 6



## TOP SIDE BOLT TENSIONER (SBT)

### Features :

- Shingare hydraulic bolt tensioners have eight load cells from M16 to M150 or from 5/8" to 5 3/4"
- Twin ports for quick connection of multiple tools.
- Only one size of bridge per size of load cell.
- Detachable and rotational bridge simplifies bolt tensioner positioning.
- Full bridge window.
- Black surface treatment protects against corrosion
- Anti-slip grip for more secure handling
- Universal and multi-use tool.
- Double Straight Reaction Arm
- Blank Reaction Arm



### Why Tensioning ?

Safe, reliable and repeatable, the use of hydraulic tensioners has many advantages over other less accurate tightening methods.

- Tension is applied directly to stretch the bolt, so we don't need to fight against friction or losses.
- The applied load is controlled very accurately, because it is directly proportional to the pressure applied to the tensioner.
- The load transfer factor is calculable, helping to give the correct residual load.
- Operation of tooling and improved accuracy reduces time required to retighten the load.
- Tensioning allows for loading multiple fasteners in a joint at the same time.
- Uniform bolt loading ensures a high level of accuracy by applying a constant force.
- Purely axial, tensile loading ensures no torsional stresses are introduced.

## SHINGARE BOLT TENSIONER (SBT)

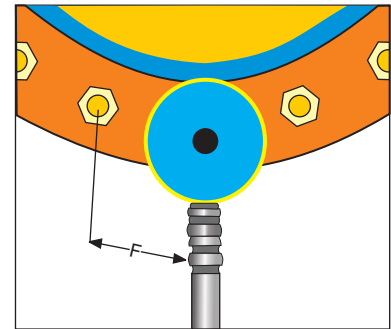
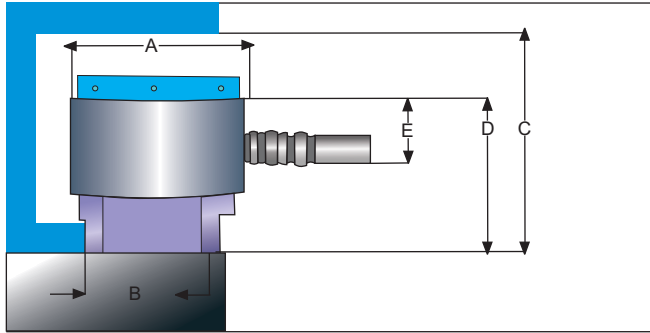

Model	Bolt Size		Cylinder	Area	Dimension						Weight
	Metric	Inch			Tons	Cm2	A	B	C	D	
SBT-3	M16	-	23.5	15.7	75	32.5	168	90	62	47-51	2
	M18	3/4"									
	M20	-									
	M22	7/8"									
	M24	1									
SBT-5	M27	1-1/8"	50	33	102	47	187	106	60	65-71	4
	M30	-									
	M33	1-1/4"									
	M36	1-3/8"									
	M39	1-1/2"									
SBT-9	M39	1-1/2"	90	59.7	133	61	208	120	60	86-93	6
	M42	1-5/8"									
	M45	1-3/4"									
	M48	1-7/8"									
SBT-13	M52	2"	130	83	163	73	231	135	62	106-114	10
	M56	2-1/4"									
	M60	-									
	M64	2-1/2"									
SBT-19	M64	2-1/2"	190	123	193	86.5	254	150	62	129-135	15
	M68	-									
	M72	2-3/4"									
	M76	3"									
SBT-27	M76	3"	270	176	233	110	286	180	73	155-167	24
	M80	-									
	M85	3-1/4"									
	M90	3-1/2"									
	M95	3-3/4"									
M100	4"										
SBT-44	M110	4-1/2"	440	251	280	111-121	304-338	181-197	37-40	210-233	45
	M120	4-3/4"									
	M125	5"									
SBT-54	M130	5-1/4"	540	317	325	126-141	354-388	202-216	42-47	243-275	73
	M140	5-1/2"									
	M150	5-3/4"									

## TS SERIES MULTI-STAGE BOLT TENSIONERS

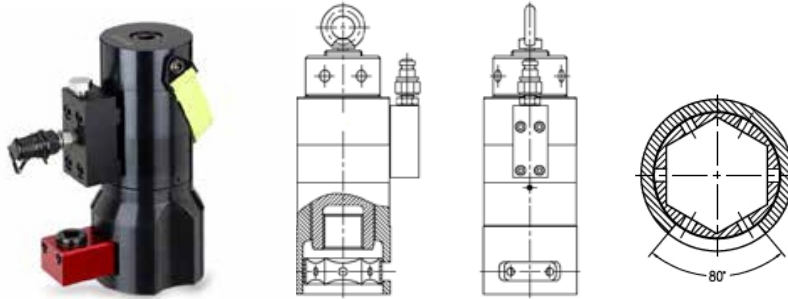

### Features and benefits

- Relatively smaller dimension with higher.
- Multi-stage design, maximize the tensioning Length
- Suitable for single type bolt tensioning, high
- Max. Pressure: 1500 Bar
- Can be operated with ultra high pressure hand pump, air pump and electric pump

Customers can fill the form below for us to chose the right desgin of multi-stage bolt tensioners for your solutions.

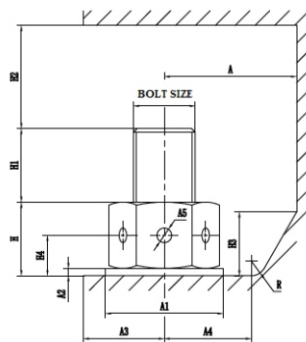

THREAD \_\_\_\_\_.

ADJACENT BOLT CENTER DISTANCE \_\_\_\_\_ mm.

BOLT TYPE(ROUND/HEX) \_\_\_\_\_.

BOLT SIZE \_\_\_\_\_.

BOLT TENSION FORCE \_\_\_\_\_ KN.

BOLT QTY. \_\_\_\_\_.

WORKING TEM. \_\_\_\_\_ OC .

A: \_\_\_\_\_ MM

A1: \_\_\_\_\_ MM

A2: \_\_\_\_\_ MM

A3: \_\_\_\_\_ MM

A4: \_\_\_\_\_ MM

A5: \_\_\_\_\_ MM

H: \_\_\_\_\_ MM

H1: \_\_\_\_\_ MM

H2: \_\_\_\_\_ MM

H3: \_\_\_\_\_ MM

H4: \_\_\_\_\_ MM

R: \_\_\_\_\_ MM

## ELECTRIC POWERPACK FOR BOLT TENSIONER (BETP)



### Features of Power Pack:

- Brand new technology: Combine unit of Low pressure and high pressure equipments.
- Less High pressure component used, hence maintenance cost is less.
- All components are Highly precise and reputed make.
- Substantial savings in energy and oil consumption.
- Analog or Digital pressure gauges assure the highest possible read out and adjustment precision.
- High speed/flow.
- Remotely operation forward and reverse.
- Light weight & compact design.

### Optional Accessories:

- High pressure hose
- High pressure QRC (Quick Release Coupling)
- Digital Pressure Gauge

**Tensioning Pump - Model BETP-1500 (Tensioning Pump)**

Tensioning Pump - Model BETP-1500 (Tensioning Pump)		
<b>Pump</b>		
Main Voltage	AC	230 V, 50Hz
Solenoid Voltage	AC	230 V
Main Consumption	A	10
Motor Capacity	kW	1.5
Protected According to	IP	IP 55
Nominal Pressure	bar	0-1500
<b>Flow</b>		
Flow @ 1500 Bar	lpm	0.1 @ 1500 bar
Tank Volume	litre	14
Oil Type		Servo 68
Ambient Temperature	C	45°
Max Oil Temperature	C	60°
<b>Weight</b>		
Weight without oil	Kg	35 Approx



## BHARTIYA AIR OPERATED TENSIONER PUMP (BATP)



The air operated powerpack for bolt tensioner BATP-1500 are designed to meet the highest technical and safety requirements of high pressure equipment.

### Technical Features

- **Stainless Steel Frame:** The hydraulic unit is installed in a weather proof stainless steel protection frame.
- **Logical Control Panel:** Logical layout design engraved for easy operation.
- **Calibrated Pressure Gauge:** Calibrated 150mm (6"), liquid filled, SS Frame, 2500 bar rating pressure gauge with dual reading of bar & psi.
- **Complete Air System:** System includes FRL Unit, air pressure gauge and control knob for safe air control and supply.
- **Higher Operating Pressure:** Pump has max working pressure of 1500 bar to cover all bolt tensioning applications.
- **Light Weight:** Unit weighs only 18 Kg and measures 450mm x 340mm x 480mm.
- **Lower Input air Pressure:** Higher pressure ratio of 1 : 350 ensures less input air pressure for operation.
- **Quick Connect Outlet:** Pump comes fitted with quick connect outlet for easy connection of hydraulic hose.

### Optional Accessories:

- High pressure hose
- High pressure QRC (Quick Release Coupling)
- Digital Pressure Gauge

Technical Details - Model BATP-1500 (Bhartiya Air Operated Tensioner Pump)		
<b>Pump</b>		
Pressure Ratio		1:350
Displacement Volume	cm <sup>3</sup>	1.3
Operating Pressure, Max. ( at 5.1 bar Pre Limited (PL) Air Pressure )	bar	1800
<b>Compressed air supply (air drive)</b>		
System Operating Air Pressure, Max.	bar	5.1
Safety Valve Set Pressure	bar	5.5
<b>Stainless Steel Tank Capacity</b>		
Oil Tank capacity	litre	5

## HAND PUMP FOR BOLT TENSIONER (SHP)



The SHINGARE double stage hand pumps comes with pressure gauge as standard, this gives the user precise and safe control over the work carried out. The gauge is directly mounted onto the pump and is well protected by the specially designed pump lever.

### Features

- Return connections on all pumps.
- Robust design
- Aluminium tank.
- Easy and simple maintenance

**Model No. : SHP**

**Maximum Working Pressure :- 1600 Bar**

Pump Type	Usable Oil Capacity	Model Number	Pressure Rating		Output Oil Volume Each Stroke		Handle Force	Dimensions (mm)			Output Adapter	Weight
			(Bar)		(cm <sup>3</sup> )			A	B	C		
	(cm <sup>3</sup> )	Nm	1st Stage	2nd Stage	1st Stage	2nd Stage	(N)				(Kg)	
Double Speed	655	SHP 7 - 0.7	25	700	15	2.6	300	520	133	119	NPT 3/8" G 1/4"	5.3
	1440	SHP 7-1	25	700	32	2.5		577	120	170		6.3
	2200	SHP 7-2	25	700	16	2.5		539	146	170		8
	3240	SHP 7-3	25	700	32	2.5		582	200	170		10
	5860	SHP 7-4	25	700	32	2.5		667	250	172		14.5
	7500	SHP 7-8	14	700	126	4.8		742	308	270		27
	1440	SHP 16-1	15	1600	32	2.5	375	577	577	170		6.3
	3240	SHP 16-3	15	1600	32	2.5		577	140	190		10

# HYDRAULIC TORQUE WRENCH



Nominal Size		Flange Size																	
		150			300			600			900			1500			2500		
Inches	Metric	No. of Bolts	Bolt dia inches	Bolt dia mm	No. of Bolts	Bolt dia inches	Bolt dia mm	No. of Bolts	Bolt dia inches	Bolt dia mm	No. of Bolts	Bolt dia inches	Bolt dia mm	No. of Bolts	Bolt dia inches	Bolt dia mm	No. of Bolts	Bolt dia inches	Bolt dia mm
1/2	15	4	1/2	14	4	1/2	14	4	1/2	14	4	3/4	20	4	3/4	20	4	3/4	20
3/4	20	4	1/2	14	4	5/8	16	4	5/8	16	4	3/4	20	4	3/4	20	4	3/4	20
1	25	4	1/2	14	4	5/8	16	4	5/8	16	4	7/8	24	4	7/8	24	4	7/8	24
1.1/4	32	4	1/2	14	4	5/8	16	4	5/8	16	4	7/8	24	4	7/8	24	4	1	27
1.1/2	40	4	1/2	14	4	3/4	20	4	3/4	20	4	1	27	4	1	27	4	1.1/8	30
2	50	4	5/8	16	8	5/8	16	8	5/8	20	8	7/8	24	8	7/8	24	8	1	27
2.1/2	65	4	5/8	16	8	3/4	20	8	3/4	20	8	1	27	8	1	27	8	1.1/8	30
3	80	4	5/8	16	8	3/4	20	8	3/4	20	8	7/8	24	8	1.1/8	30	8	1.1/4	33
3.1/2	90	8	5/8	20	8	3/4	20	8	7/8	22	-	-	-	-	-	-	-	-	-
4	100	8	5/8	20	8	3/4	20	8	7/8	24	8	1.1/8	30	8	1.1/4	33	8	1.1/2	39
5	125	8	3/4	20	6	3/4	20	8	1	27	8	1.1/4	33	8	1.1/2	39	8	1.3/4	45
6	150	8	3/4	20	12	3/4	24	12	1	27	12	1.1/8	30	12	1.3/8	36	8	2	52
8	200	8	3/4	24	12	7/8	27	12	1.1/8	30	12	1.3/8	36	12	1.5/8	42	12	2	52
10	250	12	7/8	24	16	1	30	16	1.1/4	33	16	1.3/8	35	12	1.7/8	48	12	2.1/2	64
12	300	12	7/8	27	16	1.1/8	30	20	1.1/4	33	20	1.3/8	36	12	2	52	12	2.3/4	70
14	350	12	1	27	20	1.1/8	33	20	1.3/8	36	20	1.1/2	39	16	2.1/4	56			
16	400	16	1	30	20	1.1/4	33	20	1.1/2	39	20	1.5/8	42	16	2.1/2	54			
18	450	16	1.1/8	30	24	1.1/4	33	20	1.5/8	42	20	1.7/8	48	16	2.3/4	70			
20	500	20	1.1/8	33	24	1.1/4	33	24	1.5/8	42	20	2	52	16	3	76			
24	600	20	1.1/4	33	24	1.1/2	42	24	1.7/8	48	20	2.1/2	64	16	3.1/2	90			
26	650	24	1.1/2	33	28	1.1/4	42	24	1.3/4	48	20	1	70						
28	700	28	1.1/2	33	28	1.1/2	45	28	2	52	16	3	76						
30	750	28	1.1/2	33	28	1.3/4	40	28	2	52	20	3	76						
32	800	28	1.1/2	39	28	1.1/4	48	28	2.1/2	56	20	3.1/2	85						
34	850	32	1.1/2	39	28	1.1/2	48	28	2.1/2	56	20	3.1/2	90						
36	900	32	1.1/2	39	32	2	52	28	2.1/2	64	20	3.1/2	90						

# HYDRAULIC TORQUE WRENCH



Bolt Size	A/F	Bolt Grade: 8.8				Bolt Grade: 10.9				Bolt Grade: 12.9				Bolt Size	A/F	Bolt Grade: B7/B16			
		Torque Values (Nm)			Tension (KN)	Torque Values (Nm)			Tension (KN)	Torque Values (Nm)			Tension (KN)			Torque Values (Nm)			Tension (KN)
		$\mu=0.10$	$\mu=0.15$	$\mu=0.2$		$\mu=0.10$	$\mu=0.15$	$\mu=0.2$		$\mu=0.10$	$\mu=0.15$	$\mu=0.2$				$\mu=0.10$	$\mu=0.15$	$\mu=0.2$	
M16	24	121	165	208	54	171	232	292	76	205	278	351	91	5/8"	1.1/16"	126	171	215	57
M18	27	165	224	283	66	233	316	399	92	279	379	478	111						
M20	30	237	322	406	85	333	452	571	119	400	543	685	143	3/4"	1.1/4"	226	306	387	85
M22	32	327	443	560	106	459	623	787	149	551	748	945	179	7/8"	1.7/16"	366	496	627	117
M24	36	409	556	702	122	576	781	987	171	691	938	1184	206	1"	1.5/8"	549	745	941	154
M27	41	608	828	1043	161	855	1161	1467	226	1027	1393	1760	272						
M30	46	820	1113	1406	195	1154	1566	1978	275	1384	1879	2373	330	1.1/8"	1.13/6"	816	1107	1398	204
M33	50	1128	1531	1933	244	1586	2152	2719	343	1903	2583	3263	412	1.1/4"	2"	1157	1570	1983	260
M36	55	1442	1957	2472	286	2028	2752	3476	402	2433	3302	4171	483	1.3/8"	2.3/16"	1582	2147	2712	324
M39	60	1881	2553	3225	345	2646	3590	4535	485	3175	4308	5442	581	1.1/2"	2.3/8"	2100	2850	3600	394
M42	65	2317	3145	2973	394	3259	4423	5587	554	3911	5307	6704	665	1.5/8"	2.9/16"	2720	3692	4663	471
M45	70	2912	3952	4992	462	4095	5558	7021	650	4914	6670	8425	780	1.3/4"	2.3/4"	3452	4685	5917	555
M48	75	3490	4737	5984	519	4909	6662	8415	730	5890	7994	10097	877	1.7/8"	2.15/16"	4304	5841	7378	645
M52	80	4545	6169	7792	624	6392	8675	10958	878	7670	10410	13149	1054	2"	3.1/8"	5285	7173	9060	743
M56	85	5642	7658	9673	720	7935	10768	13602	1012	9522	12922	16323	1214	2.1/4"	3.1/2"	7674	10414	13155	959
M60	90	7076	9603	12130	842	9951	13504	17058	1185	11941	16205	20470	1422						
M64	95	8535	11583	14631	953	12002	16289	20575	1340	14403	19547	24690	1607	2.1/2"	3.7/8"	10691	14509	18327	1203
M68	100	10405	14121	17838	1093	14632	19858	25084	1537	17559	23830	30101	1844	2.3/4"	4.1/4"	13038	17694	22350	1333
M72	105	12530	17005	21480	1243	17620	23913	30206	1748										
M76	110	14926	20256	25587	1403	20989	28485	35981	1973										
M80	115	17608	30185	1572	1572									3"	4.5/8"	17104	23213	29321	1603
M85	120	21390	29029	36668	1797														
M90	130	25676	34847	44017	2038									3.1/4"	5"	21938	29774	37609	1898
M95	135	30500	41393	52286	2293									3.1/2"	5.3/8"	27607	37467	47326	2218
M100	145	35893	48712	61531	2564									3.3/4"	5.3/4"	34176	46382	58588	2563
M105	150	41886	56846	71805	2849									4"	6.1/8"	41712	56610	71507	2933
M110	155	48511	65837	83162	3150														

$\mu=0.10$  - Lubricated Bolts  
 $\mu=0.15$  - Semi Lubricated Bolts  
 $\mu=0.2$  - Dry Bolts

Newton - Meter Nm to Foot-Pounds lbf. ft. (1Nm = 0.738 lbf. ft.)  
 Kilogram - Force Meter to Newton - Meter (1 Kgm = 9.80 Nm)



## OUR MAJOR CLIENTS

Please see below our robust and valued client list that uses BHARTIYA products repeatedly. We take pride in our partnerships and the ability to grow with such amazing group of companies.



**SHINGARE**  
INDUSTRIES PVT LTD

**SHINGARE INDUSTRIES PVT. LTD.**  
Formerly known as Bharatiya Industries  
Manufacturer & Exporter of Tube Cleaners, Flexible Shafts, Tube Tools, Pipe Beveling Machines, Torque Tools, Grinding Tools, Tapping Tools.  
A-48 B Osiya Mataji Compound, Village Kalher, Retibunder Road, Tal. Bhiwandi, Dist. Thane - 421302, Maharashtra,  
+91 22 25854509 | +91 90290 05461 | +91 22 25883527 | bharatflex@yahoo.com | spradip@tubecleaner.co.in  
www.shingare.com | www.tubecleaner.co.in

*Authorised Dealer*